

"ADORATION" EARRINGS



Design, Graphics, Photographs and Instructions by Joanie Jenniges, Copyright 2007

adoration n. the act of paying honor, reverent homage or fervent and devoted love

website: www.beadworkdesigns.com

email: joanie@beadworkdesigns.com

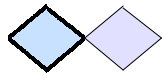
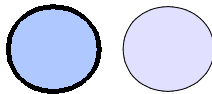
SUPPLY LIST:

8	4 mm	Swarovski Bicone Crystals	
2	6mm	Swarovski Round Crystals	
20	Size 11	Japanese Seed Beads (SB)	
60	Size 14/15	Japanese Seed Beads (sb)	
2		Ear Wires, Gold Filled or Sterling Silver	
2	1-inch	Headpins, Gold Filled or Sterling Silver	
1	Size 12	Beading Needle	
4 feet	Size D	Fireline (6 pound - Fine), Nymo or Silimide	
		Thread Conditioner (If Using Nymo)	

Scissors, Chainnose and Roundnose Pliers, Cheaters ☺

NOTES:

1. PT (pass through): Pass needle through beads in the same direction as previous pass(es)
2. PBT (pass back through): Pass needle through beads in opposite direction as previous pass(es)
3. Faded beads and lines indicate previous step(s)
4. All seed beads **MUST** have fully opened large holes and be of consistent shape and size



You **MAY** use this design, instructions, graphics and photographs to create items for personal use, gifts or "pin money" only, but **DO NOT** mass produce items; reproduce, sell or copy this design or these instructions, graphics and photographs, or use this design or instructions in teaching, with kits or in judged contests without the permission of Joanie Jenniges. Thanks!

"ADORATION" EARRINGS

Design, Graphics, Photographs and Instructions by Joanie Jenniges, Copyright 2007

website: www.beadworkdesigns.com

email: joanie@beadworkdesigns.com

Page 2

Step 1:

Thread (and condition if needed) 2 feet of the threading material. Using a single strand and leaving a 6-inch tail:

Step 2:

- A: STRING:** One Size 11 SB (A), One 4mm Crystal (1), One Size 11 SB (B), One 4mm Crystal (2), One Size 11 SB (C), One 4mm Crystal (3), One Size 11 SB (D), One 4mm Crystal (4),

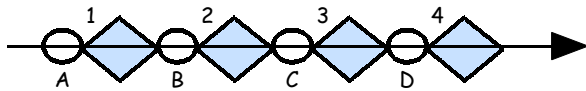

- B: TIE:** Tie the beads into a circle, using a square or surgeon's knot (SOLID LINE)

- C: PT:** All EIGHT BEADS strung in THIS STEP; and then again through the FIRST TWO BEADS strung (SB A and Crystal 1 - DASHED LINE)

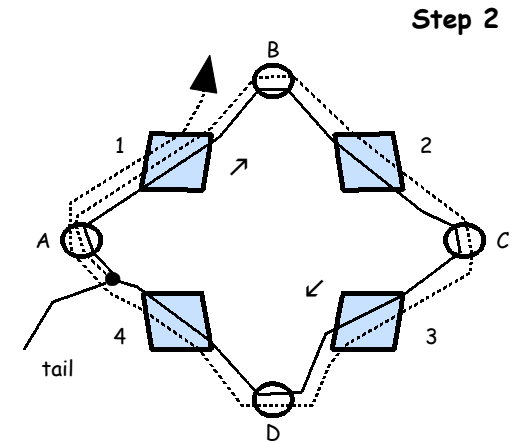

Step 3:

- A: STRING:** One Size 14/15 sb (a), One Size 11 SB (E), One Size 14/15 sb (b)



- B: PT:** The SECOND Crystal strung in STEP 2

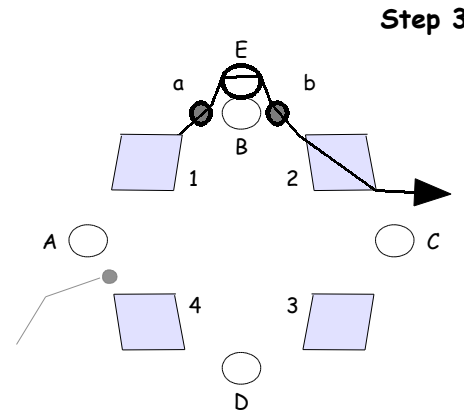

Step 4:

- A: STRING:** One Size 14/15 sb (c), One Size 11 SB (F), One Size 14/15 sb (d)



- B: PT:** The THIRD Crystal strung in STEP 2

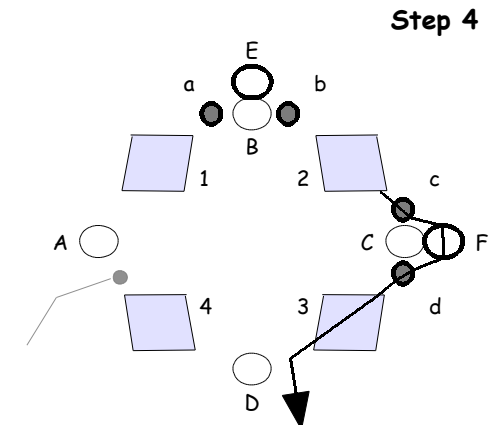

"ADORATION" EARRINGS

Design, Graphics, Photographs and Instructions by Joanie Jenniges, Copyright 2007

website: www.beadworkdesigns.com

Page 3

email: joanie@beadworkdesigns.com

Step 5:

- A:** STRING: One Size 14/15 sb (e), One Size 11 SB (G),
One Size 14/15 sb (f)



- B:** PT: The FOURTH Crystal strung in STEP 2

Step 6:

- A:** STRING: One Size 14/15 sb (g), One Size 11 SB (H),
One Size 14/15 sb (h)

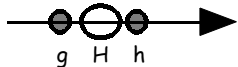

- B:** PT: The FIRST Crystal strung in STEP 2, and ALL THE BEADS either STRUNG or PASSED THROUGH in STEPS 3 through 6.

- C:** PT: The FIRST Size 14/15 sb strung in STEP 3 (a)

Step 7:

- A:** STRING: Six Size 14/15 sbs (i through n)



- B:** PT: The SECOND Size 14/15 sb strung in STEP 3 (b), the SECOND Crystal strung in STEP 2, and the FIRST Size 14/15 sb strung in STEP 4 (c)

- C:** STRING: Five Size 14/15 sbs (o through s)



- D:** PT: The SECOND Size 14/15 sb strung in STEP 4 (d), the THIRD Crystal strung in STEP 2, and the FIRST Size 14/15 sb strung in STEP 5 (e)

Step 5

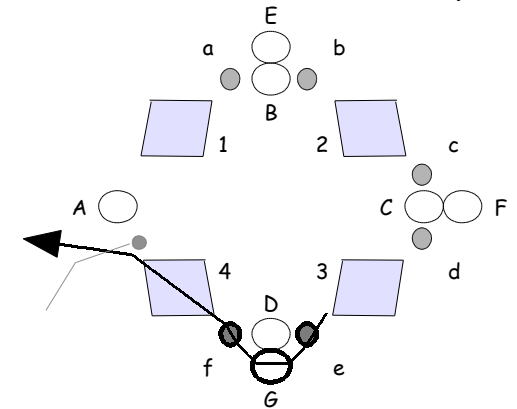

Step 6

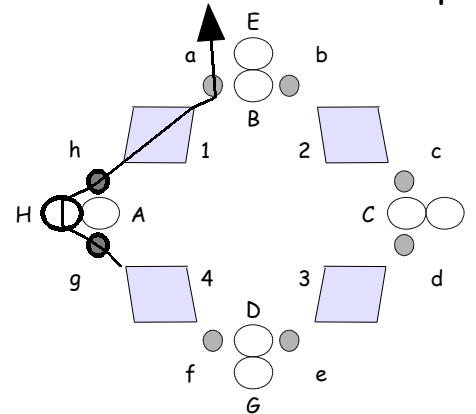

Step 7

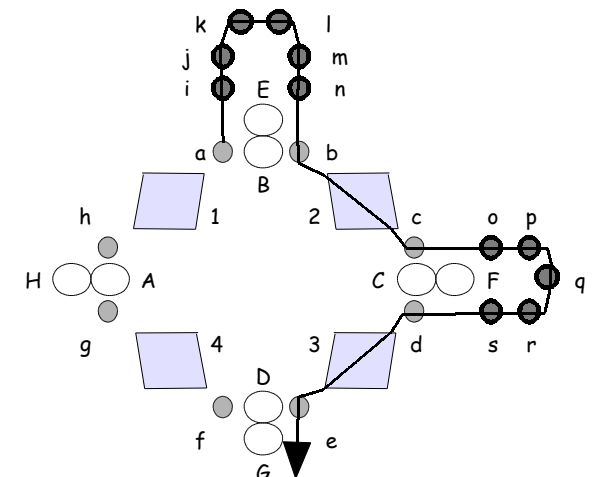

"ADORATION" EARRINGS

Design, Graphics, Photographs and Instructions by Joanie Jenniges, Copyright 2007

website: www.beadworkdesigns.com

Page 4

email: joanie@beadworkdesigns.com

Step 8:

A: STRING: Six Size 14/15 sbs (m through t)



B: PT: The **SECOND** Size 14/15 sb strung in STEP 5 (f), the **FOURTH** Crystal strung in STEP 2, and the **FIRST** Size 14/15 sb strung in STEP 6 (g)

C: STRING: Five Size 14/15 sbs (z, aa through dd)

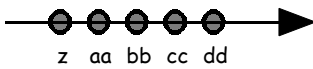

D: PT: The **SECOND** Size 14/15 sb strung in STEP 6 (h), the **FIRST** Crystal strung in STEP 2, and the **FIRST** Size 14/15 sb strung in STEP 3 (SOLID LINE) **AND** ALL of the BEADS either strung or passed through in STEPS 7 and 8 to reinforce (DASHED LINE)

E: WEAVE IN both the WORKING and TAIL threads, tying half-hitch knots and weaving in after final knots; clip threads

Step 9:

A: On ONE Headpin:

B: STRING: One Size 11 SB, One 6mm Crystal, One Size 11 SB

C: TURNING LOOP: Turn a simple loop that is large enough to fit through the Size 14/15 sb loop strung in STEP 8

D: CAREFULLY ATTACH the 6mm Crystal DROP to the Size 14/15 sb loop that was strung in STEP 8

E: CAREFULLY ATTACH the EARWIRE to the Size 14/15 sb loop that was strung in STEP 7

REPEAT STEPS ONE THROUGH NINE FOR THE SECOND EARRING

Enjoy "Adoration" Earrings with my very best wishes - Joanie

Step 8

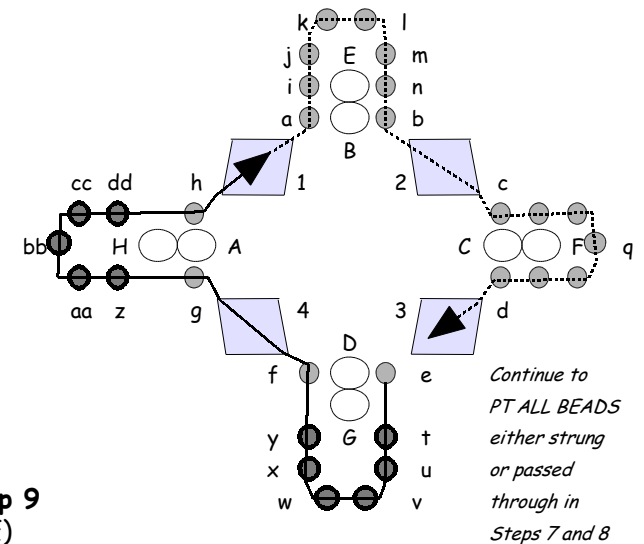

Step 9 (E)

Step 9 (A-C)

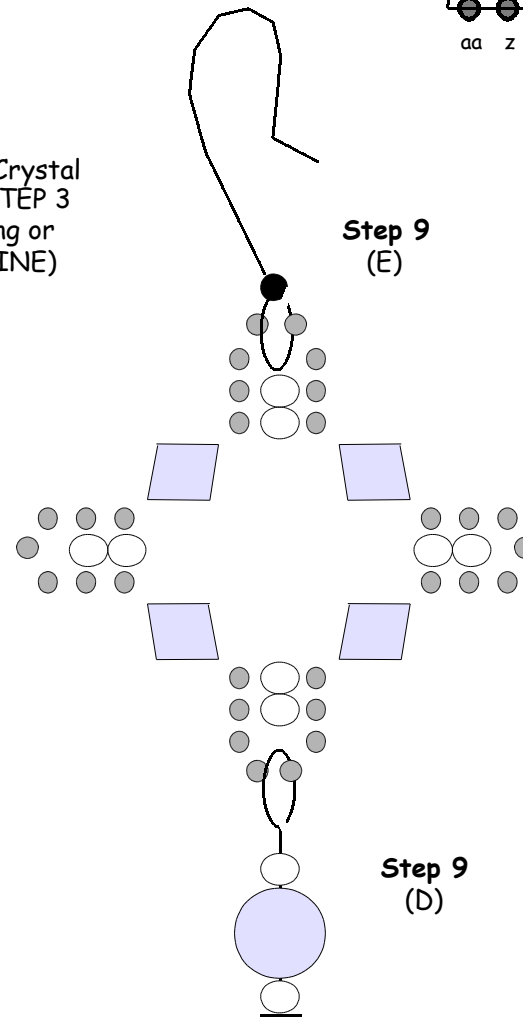

Step 9 (D)